

PLS12

AUTOMATIC UNIVERSAL LINER SIZER

PART # 39021



DURO[®]
DYNE
MACHINERY
DIVISION

OWNER'S MANUAL

LIMITED WARRANTY

Duro Dyne Machinery is manufactured by skilled mechanics, utilizing the latest production techniques. Each unit has been rigorously tested prior to packaging and shipment in order to ensure trouble-free operation.

Your Duro Dyne machine has a one year warranty against defects in material. Any component found to be defective will be repaired or replaced (at manufacturer's discretion) at no cost if faulty component is returned freight prepaid to the nearest Duro Dyne Service Department. Warranty does not apply to expendable parts (cutting blades, etc.) or repairs or service due to improper maintenance or operation procedures.

TABLE OF CONTENTS

INTRODUCTION	3
INSTALLATION INSTRUCTIONS	4-5
CONTROLS	4
OPERATION	5
MAINTENANCE	5
TROUBLESHOOTING	6-8
THEORY OF OPERATION	9
SERVICING	9



INTRODUCTION

The PLSU2 Automatic Liner Sizer has primarily two Parts; one called the Cradle Assembly, the other called the Cutting and Slitting Section. It is suggested that a run out table be used in conjunction with the machine.

The cradle assembly consists of: The cradle, and two pairs of bearing mounted rollers to accommodate up to 2 rolls of 60'' Liner up to 2'' thick.

When building the run out table it is important that a two inch clearance gap be left between the angle iron and the table frame from the cutting head to the far leg so that the light beam of the length sizer (located in the control module) is unobstructed. Safety interlocks under the guards, (see cradle and crosscut view) will not allow the machine to operate if the guards are removed. Do not remove safety guards and render safety micro-switches inoperative. **The PLSU2 has moving blades which can cause serious injury should the safety features be over ridden. Disconnect air and electric supply before servicing the PLSU2.**

To insure square and accurate sizing, the cradle support angles and the nine foot angle guides should be mounted at 90° degree angles to the cutting head.

Important: Always follow manufacturer's recommendations for proper safety and handling procedures for all materials used in conjunction with this machine as outlined in Manufacturer's Safety Data Sheet (MSDS) for each product.

INSTALLATION INSTRUCTIONS

NOTE: Do not tighten bolts and nuts until unit is completely assembled. When assembling the PLSU2 be sure all components are square to each other.

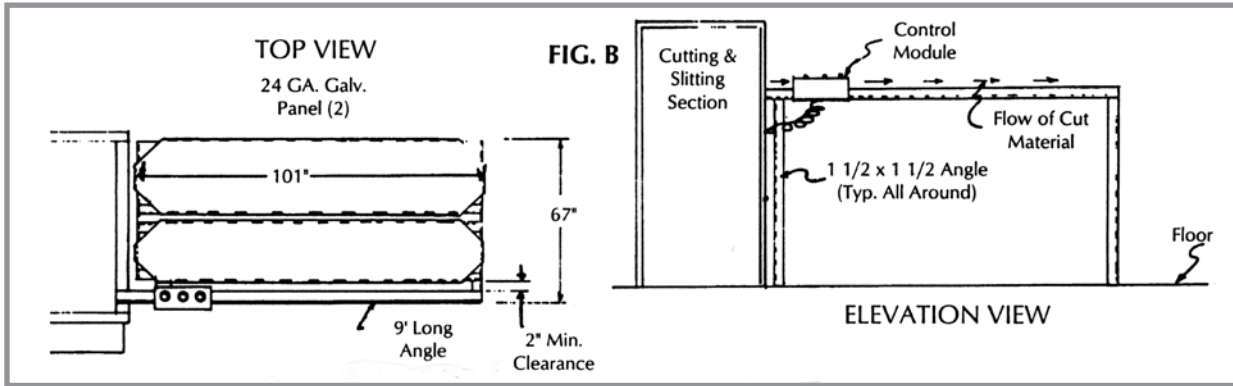

- 1) Attach 7 foot angle iron guide square to the cutting and slitting section using two 1/4 x 20 truss head bolts. (Be sure angle iron is at a right angle with the frame.)
- 2) Build a run out table similar in design to the table shown in Fig. B.
- 3) Locate the control module in the carton packed in the PLSU2 crate. Hook the control module assembly over the edge of the nine foot angle iron guide and straighten module.
- 4) Plug control module into socket located on the left/right side of exit table depending on the flow. Twist lock ring on plug to secure connection.
- 5) Locate the air regulator assembly that is located on the PLSU2. Connect the air supply.
- 6) Turn on the air and adjust the air regulator for 80 p.s.i. by turning the regulator knob counter clockwise to decrease the air pressure and clockwise to increase air pressure.

Caution: KEEP HANDS CLEAR OF CUTTING HEAD ASSEMBLIES.

CONTROLS



CONTROL MODULE AND SENSOR MOUNTING

Control Module and Sensor Mounting for Left or Right Hand Application: (the Control Module, Sensor and Keeper are pre-set from the factory for Right Hand Mount operation)

- 1) Secure the **7ft Long Angle** to the **PLSU2 Unit** as per your **Material Flow** and the side of the machine that the operator will be working from. All required hardware is pre-attached. **NOTE:** the **Feed Angle Bracket** will need to be removed and placed on the other face of the **7ft Long Angle** if you are changing the **Controls** from the **Right Hand Mount**. The **Sensor** and **Keeper** will also need to be reversed on the Track. Ensure the "open" end of the **9ft Long Angle** height is parallel to the **PLSU2 Unit** for proper operation. A mounting apparatus will be needed if not attached to a table at the required height.
- 2) Place the **Control Module**, **Sensor** and **Keeper** as shown in the appropriate view below and secure the **Control Module Cord** (not shown) to the Plug properly.

***AS NOTED BEFORE:** The PLSU2 Unit is pre-set for Right Hand Mount operation, this also applies to the Material Cradle Frame on the other side of the machine as well as the Hold Down Handle and Dog. If the 9ft Long Angle and its components are being changed to Left Hand Mount, then the Outer Ends of the Cradle Frame, Hold Down Handle and Dog also need to be changed. Re-assemble the Dog as shown below. (Please refer to the page for the Material Cradle Assembly as required.)

THE CUTTING BLADES ARE VERY SHARP, PLEASE TAKE PROPER OPERATOR SAFETY PRECAUTIONS AS NEEDED.

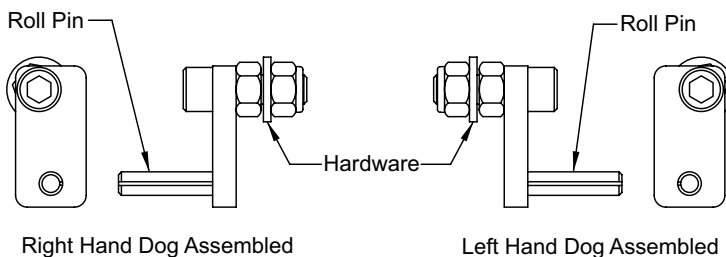
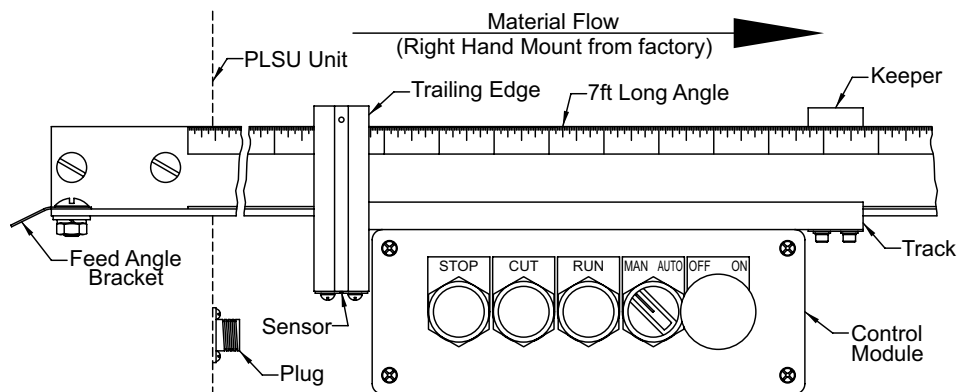
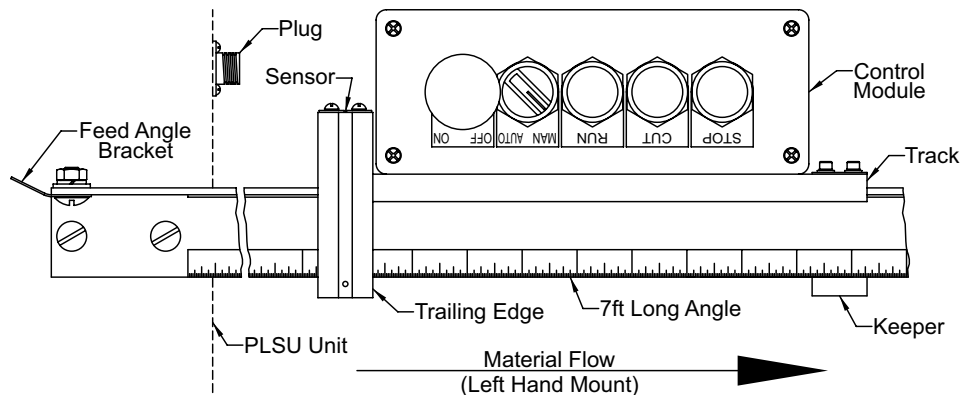

The **Dog** is also pre-set from the factory for **Right Hand Mount** operation: To change the **Dog** from **Right Hand Assembly** to **Left Hand Assembly**, reverse the **Hardware** orientation and push the **Roll Pin** through to the other face as shown at left.

MATERIAL CRADLE ASSEMBLY

IMPORTANT: THIS INSTALLATION PROCEDURE REQUIRES AT LEAST TWO PEOPLE. TAKE PROPER SAFETY PRECAUTIONS.

- 1)** PART-A (Liner Angle Left): Mounts to PLSU2 Frame Table. Use the two mounting holes that are the furthest to the outside left. Use the 1/4-20x1" bolts along with lock and flat washers. Just snug them for now.
- 2)** PART-B (Liner Angle Right): Mounts to PLSU2 Frame Table. Use the two mounting holes that are the furthest to the outside right. Use the 1/4-20x1" bolts along with lock and flat washers. Just snug them for now.
- 3)** PART-C (Liner Guide Rollers & Roller Bracket Assembly): Slide over PARTS-A and B and secure at the sixth hole in. Mount the Roller Brackets with the 3/8-16x1" bolts along with lock washers, flat washers and 3/8-16 nuts. Just snug them for now. If the Rollers do not spin freely at this point, PART-A and B may have to be slid inwards to loosen the tension on the PART-C Bracket.
- 4)** PART-D (Upright Legs with (2) Roller Support Channels mounted on it): Mount it to PART-A so that the Roller Support Channel faces away from the machine. Use Square U-Bolt, Square U-Bolt Mounting Plates and 3/8 lock washers and 3/8-16 nuts to mount channels. Mount to the outside of PART-A. Just snug them for now.
- 5)** PART-E (Rear Cross Brace): Mount to the bottom and top of PARTS-D. Angle should go under and over PARTS-D and face the outside. Use the 3/8-16x2.5" bolts along with flat washers, lock washers and 3/8-16 nuts. Just snug them for now.
- 6)** PART-F (Liner Angle Brace Left): Mount the slotted end to the angled end of PART-A in the outside hole. Use 3/8-16x1" bolt along with flat washers, lock washers and 3/8-16 nuts. Just snug them for now. Mount lower PART-F to lower PART-D. Use 3/8-16x3" bolt along with flat washers, lock washers and 3/8-16 nuts. Just snug them for now.
- 7)** PART-G (Liner Angle Brace Right): Mount the slotted end to the angled end of PART-B in the outside hole. Use 3/8-16x1" bolt along with flat washers, lock washers and 3/8-16 nuts. Just snug them for now. Mount lower PART-G to lower PART-D. Use 3/8-16x3" bolt along with flat washers, lock washers and 3/8-16 nuts. Just snug them for now.
- 8)** PART-H (Front Cross Brace): Mount between and under PARTS-A and B using the holes closest to the machine. Use 3/8-16" bolts along with flat washers, lock washers and 3/8-16 nuts. Just snug them for now.
- 9) Level all horizontal parts. Straighten all vertical parts. Now tighten all nuts and bolts.**
- 10)** PART-I (Liner Guide Bar Assembly-Fixed): Mount to the remaining holes on PARTS-A and B. Use 1/4-20x1" bolts along with flat washers and lock washers.
- 11)** PART-J (Hold Down Bar): Mount one to the top of parts-D. Use 3/8-16x3" bolts along with flat washers and nylon locking nut. Mount the other to the middle of PARTS-D. Just tighten down enough so bar is snug but can move freely up and down.
- 12)** PART-K (Insulation Support Bars): Mount on Roller Support Channels attached to PARTS-D.
- 13)** PART-L (Liner Feed Guide): May have to be relocated to other side of machine depending on insulation flow.

MATERIAL CRADLE ASSEMBLY DIAGRAM

IMPORTANT: THIS INSTALLATION PROCEDURE REQUIRES AT LEAST TWO PEOPLE. TAKE PROPER SAFETY PRECAUTIONS.

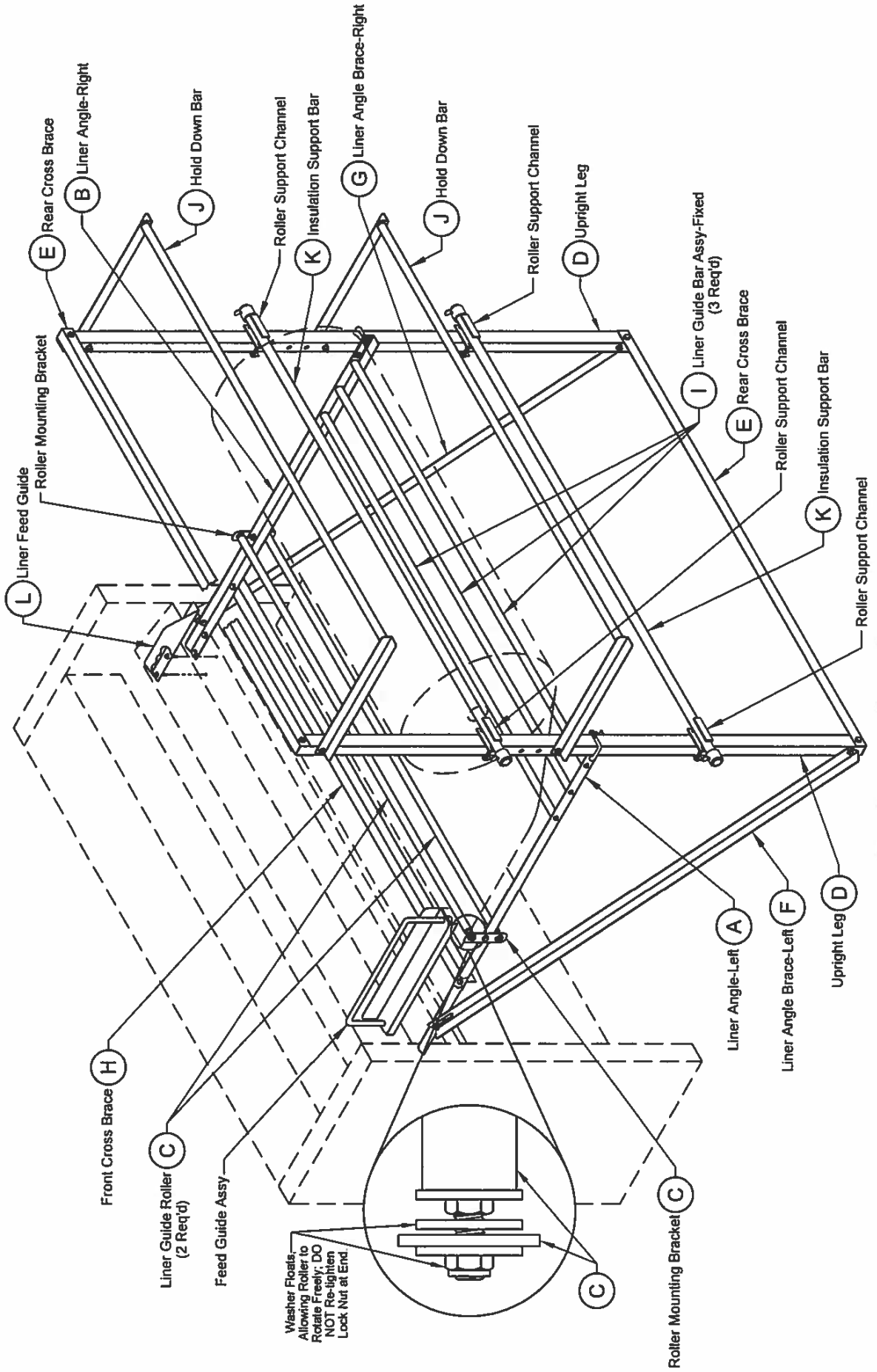

THE CUTTING BLADES ARE VERY SHARP, PLEASE TAKE PROPER OPERATOR SAFETY PRECAUTIONS AS NEEDED.

MATERIAL INSTALLATION INSTRUCTIONS

(the PLSU2 unit and its components are pre-set from the factory for Right Hand Mount operation)

- 1) Secure the **7ft Long Angle** before securing the **Material Guides**. Please refer to the instructions shown in the **Owner's Manual** or the separate instruction sheet entitled "**PLSU Control Module, Dog & Handle Installation Instructions**" provided with the PLSU2 Unit for this installation.
- 2) Secure the **Material Guide** loosely using the **Hardware** already in place. Align the inner edge of the **Material Guide** with the inner edge of the **7ft Long Angle** as shown below. The **Material Guide** must be 90deg to the **PLSU2 Unit** as shown. Tighten the **Hardware** securely.
- 3) Secure the **Material Guide** to the opposite side of the **PLSU2 Unit** loosely using the **Hardware** already in place. The **Material Guide** must be 90 deg to the **PLSU2 Unit** as shown. Tighten the **Hardware** securely.
- 4) If changing the mounting of the **7ft Long Angle** from **Right Hand Mount** operation to **Left Hand Mount** operation, then follow the same method of attachment as above from the **Left** of the machine.

**THE CUTTING BLADES ARE VERY SHARP,
PLEASE TAKE PROPER OPERATOR SAFETY PRECAUTIONS
AS NEEDED.**

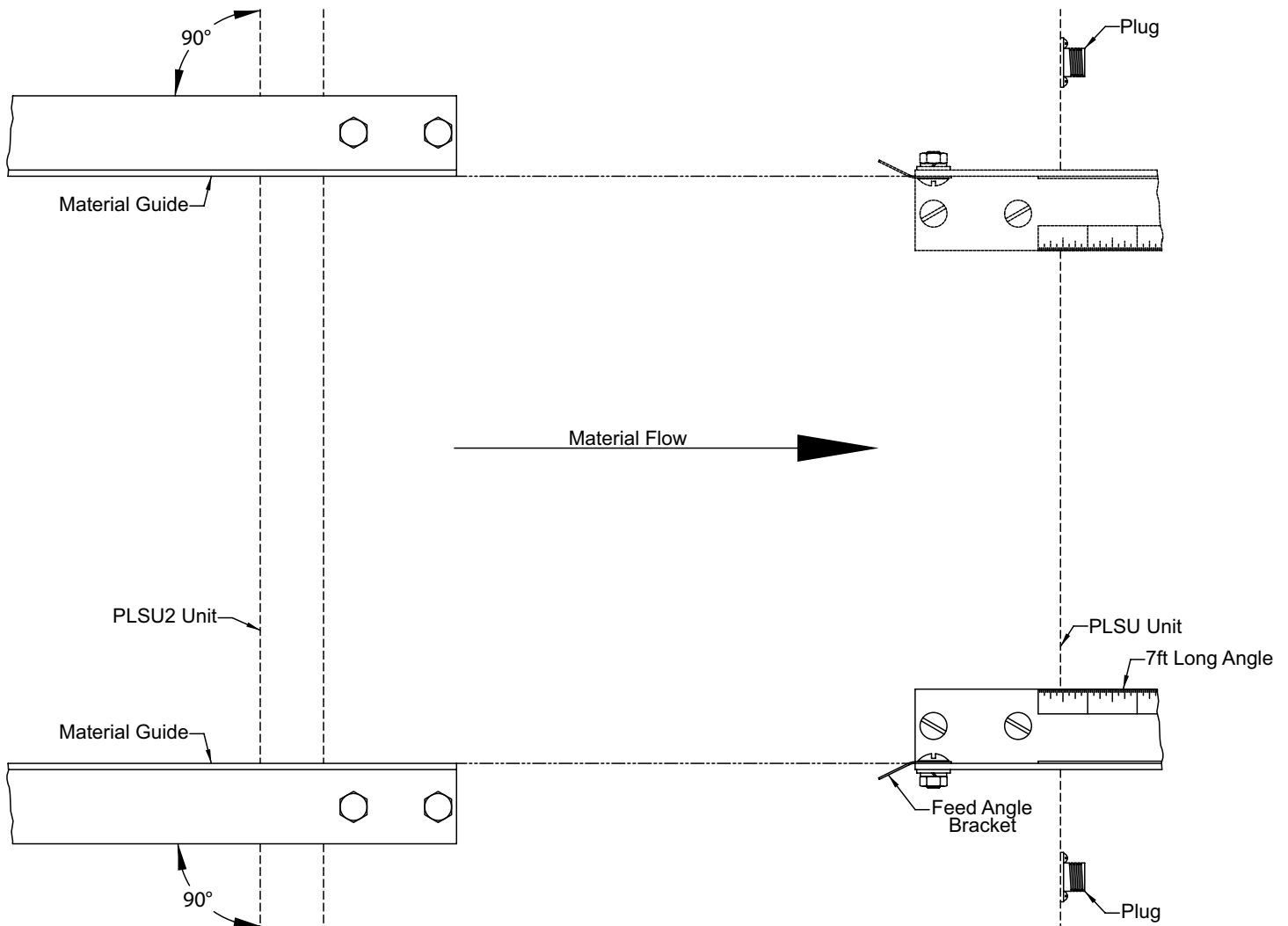

OPERATION

- 1) Plug the PLSU2 into 110 volt power supply with grounded socket.
- 2) Refer to **Pg. 3** pictorial representation of machine. Set the slitting width by loosening the knob on the slitter assembly, Align red indicator line on slitter guard with tape on plexi guard for desired liner cut width.
NOTE: Pinch Roller arm and dog assembly may be moved and assembled with the Control Module according to the desired flow of the liner.

PLSU2 CONVERSION FOR LEFT HAND OPERATION

- 3) Remove the hold down dog. Reverse the position of the pin by pressing it through to the other side of the dog. Attached the hold down dog on the opposite side of the PLSU2. The hold down dog must fall freely.
- 4) Remove the upper hold down dog handle and attach it on the opposite side of the PLSU2. Be sure that all of the set screws are firmly tightened on the flat areas on the shaft before operating the machine.
- 5) With pinch roller locked in the up position insert desired liner through pinch roller along inner face of cradle frame. Raise pinch roller and release dog. Make sure pinch roller rests securely on top of the liner.
Set Cut Length (See Illustration)
To set cut length use the trailing edge of the sensor located on the Control Module Assembly as your indicator for the cut length. Test first liner cut on manual selector switch of control module. Run liner to sensor then, press blue cut button to cut liner. Check for correct length of cut. If cut correct you may select auto run if desired for bulk quantities.
NOTE: Cross cut will cut automatically when liner reaches sensor. Once liner is removed away from sensor, liner will feed and cut automatically, and will repeat cycle.

MAINTENANCE

Air Supply Unit

- 1) To provide uninterrupted service, the air regulator assembly must be kept clean. Drain off any filter bowl accumulation before it becomes full. A visible coating of dirt or condensate on the filter element or erratic operation indicates cleaning is necessary. Wash filter element in denatured alcohol and blow it out with compressed air.
- 2) Clean bowl with household soap.
- 3) Check for leaks in air hoses
- 4) Check and adjust air pressure to 80 p.s.i. minimum. When reducing regulator pressure turn the knob counter clockwise. Cycle the machine before reading the pressure gauge. To increase air pressure repeat the procedure turning knob clockwise.

Electrical Unit

- 1) The Control Module Assembly should remain fastened securely to the 9' long angle iron; See illustration. The photo receiver must be kept clean and free of obstruction in order to insure proper response and correct functioning of cutting, timing and other operations of the control module assembly.

TROUBLESHOOTING

A) Transformer #1

Powers the contactor that supplies power to the rest of the electrical controls. High Voltage side (110vac) is connected to terminals #1 and #2 on control console. Low voltage secondary (24vac) goes to one side of contactor coil and the other side goes through the on/off switch in the control module to the other contactor coil.

B) Power on Contactor

Supplies power to the rest of the electrical controls. L1 and L2 wire to terminals #1 and #2 on the control console. T1 and T2 wire direct to L1 and L2 on the Motor Run Contactor. The Power Contactor goes on and off with the on/off switch on the control module.

C) Motor Run Contactor

Supplies power to motor and brake. L1 and L2 receive power from T1 and T2 on the Power On Contactor. T1 and T2 wire to the terminals #5 and #6 and then go to motor and brake. Coil is controlled by the short Cycle Relay in the forward mode and in the reverse mode by the Run and Stop Switches depress at the same time.

D) Transformer #2

Supplies the power to all the low voltage controls on the PLSU2 other than the Power On Contactor. High side (110vac) wires to T1 and T2 on the Power on Contactor. Low voltage secondary (24 vac) wire to terminal #11 and #13-14 on control console.

E) Brake

Stops motor after running. Applying power releases the brake and disengaging power will apply the brake. B2 and B4 in the brake are wired to terminal #6 on the Control Console and B1 and B3 are wired to terminal #5 on the Control Console.

F) Motor

Drives gears, rollers and shafts, L1 (blue and orange wire) on motor wires to terminal #5 on control console. L2 (white yellow wire) on terminal #6 on control console. Red wire from motor to terminal #4 on control console. Black wire of motor to terminal #3

G) Reverse Relay

Relay reverses directions of motor. Common contact #1 black wire to terminal #3 on control console.

Normally Closed: Contact #2 (black wire) to motor run contactor T1

Normally Open: Contact #3 (yellow wire) to motor run contactor T2

Common Contact: #4 (red wire) to terminal #4 on Control Console.

Normally Closed: Contact #5 (red wire) to T2 on motor contactor. Run normally Open contact #6 (blue wire) to T1 on motor contactor

24v coil - 1 side to terminal #26, 1 side to terminal #14 (yellow wire) to control console (purple wire)

TROUBLESHOOTING (CONTINUED)

H) Forward lockout relay

Prevents motor from going in reverse when running forward. Common contact (purple wire) to terminal #26 on control console. Normally open contact (brown wire) to one side of coil motor run contactor. Normally open on motor control relay.

I) Guard Interlocks

Prevents machine from running with guards open. #1 interlock to terminal #11 and terminal #10

#2 guard interlock to terminal #10 and terminal #12

J) Cross cut Interlock

Prevents motor running when crosscut assembly does not return home. Wire to terminal #22 (red) and #23 (black)

K) Crosscut Relay - controls crosscut solenoid blue wire terminal #3 on crosscut time delay to one side of coil and common contact on relay. Other side of coil to terminal #13 and terminal #14 on control console. Normally open contact (black wire) to terminal #16 on control console.

Normally Closed contact (black wire) to terminal #15

L) Cross Cut Solenoids

Controls cross cut cylinder one side of both coil (yellow wire) to terminal #13 and terminal #14 on control console. One side of one coil to terminal #15 (black wire) other side of coil to terminal #16

M) Motor Control Relay

Supplies power to motor on contact. Will supply power to cross cut time delay for cross cut. (Red Wire) from one side coil to terminal #23 other side of coil (yellow wire) to terminal #13 and terminal #14 of control console.

N) Mode Selector Relay

Responsible for auto mode. One side of coil (green wire) to terminal #21 other side of coil (yellow wire) to terminal #13 and terminal #14 supplies power to motor control relay cut circuit to cut. Automatically, also latches circuit to continue running.

O) Receiver Board

Located inside control module- Receiver board controls motor control relay and is controlled by sensor Terminal (A) (orange wire) one side to 24VAC terminal (B) yellow wire to other side of 24VAC Power Supply. Terminal (C) and (D) wired to photo receiver on sensor. Terminal (E) is the output to motor control relay. E is A (AC) black wire to terminal #22. This power passes through crosscut interlock to motor control relay. F is the input for motor control relay. G and H is the power supply for red LED 12 volts DC. G positive H negative.

TROUBLESHOOTING (CONTINUED)

P) Control Module

#1 - on/off switch controls power on contact. Common contactor (green wire) to terminal #25. Normally closed contactor (Blue wire) to terminal #24.

#2 Auto/manual/Switch - Controls auto mode one side of switch (Brown wire) to terminal #21 other side of switch (green wire) to common terminal on stop switch.

#3 Run Switch - motor control - goes to motor run contactor. Normally open contact (orange wire) to terminal #12 on control console. (power supply wire)

Common contact - to terminal #20 (red wire) on control console.

#4 Cut Switch - cuts liner. Normally open contact to terminal #19 (white wire) to control console.

Common contact - (orange wire) to terminal #12 (power supply)

#5 Stop Switch - Stops machine (depressed with run switch allows reverse feed)

Normally open (grey wire) to terminal #26 on control console.

Common contact for normally open - (red wire) to terminal #20 and to normally closed contact on stop switch.

Common contact for normally closed - (green wire) to one terminal on auto/manual switch #6 All switch lights are wired to orange and yellow wires 24 AC

PLSU2 WIRING DIAGRAM

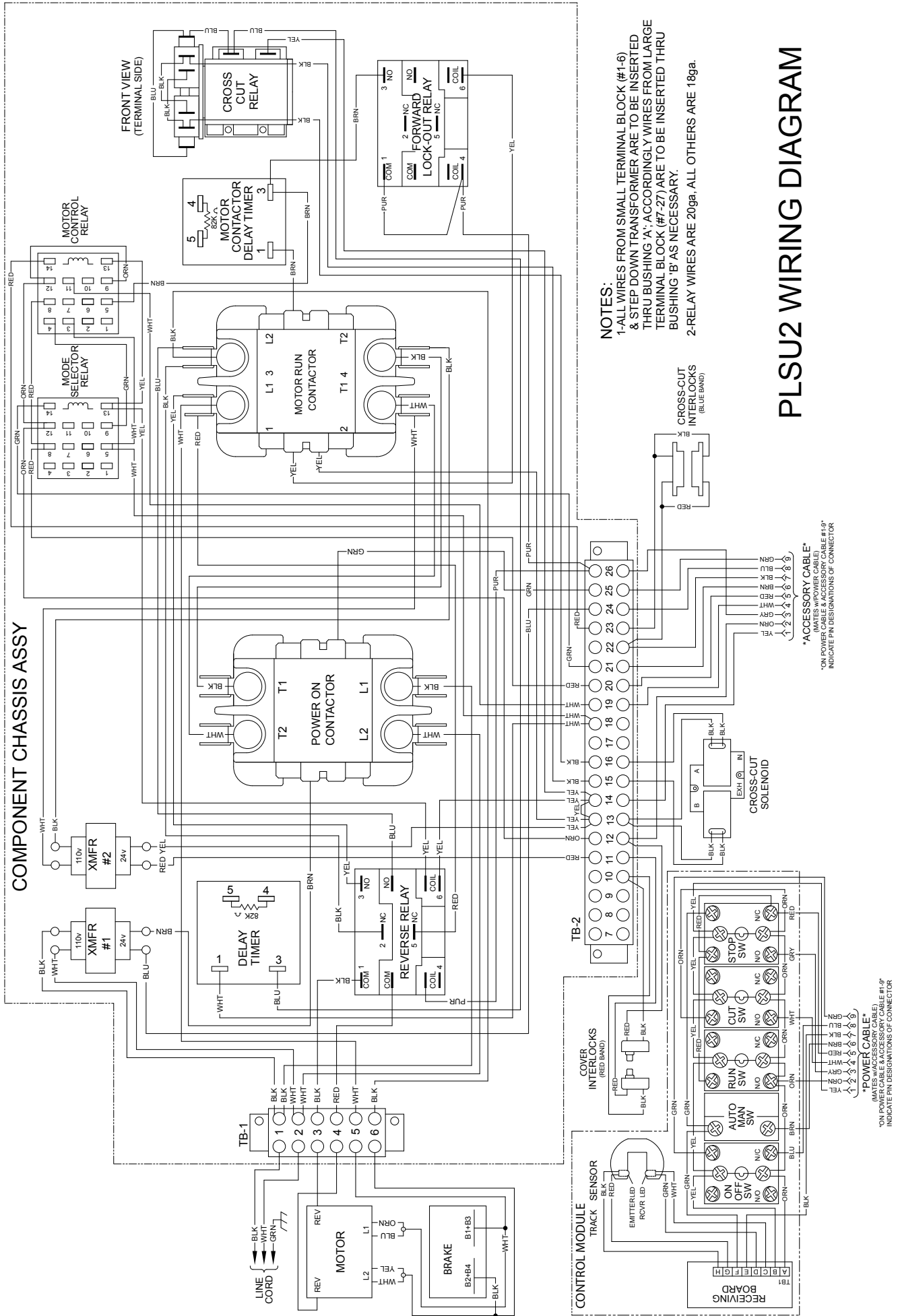

NOTES:
 1-ALL WIRES FROM SMALL TERMINAL BLOCK (#1-6) & STEP DOWN TRANSFORMER ARE TO BE INSERTED THRU BUSHING 'A'; ACCORDINGLY WIRES FROM LARGE TERMINAL BLOCK (#7-27) ARE TO BE INSERTED THRU BUSHING 'B' AS NECESSARY.
 2-RELAY WIRES ARE 20ga. ALL OTHERS ARE 18ga.

PLSU2 WIRING DIAGRAM

ACCESSORY CABLE
 (MATES W/ACCESSORY CABLE)
 INDICATE PIN DESIGNATIONS OF CONNECTOR

POWER CABLE
 (MATES W/ACCESSORY CABLE)
 INDICATE PIN DESIGNATIONS OF CONNECTOR

PLSU2 SCHEMATIC

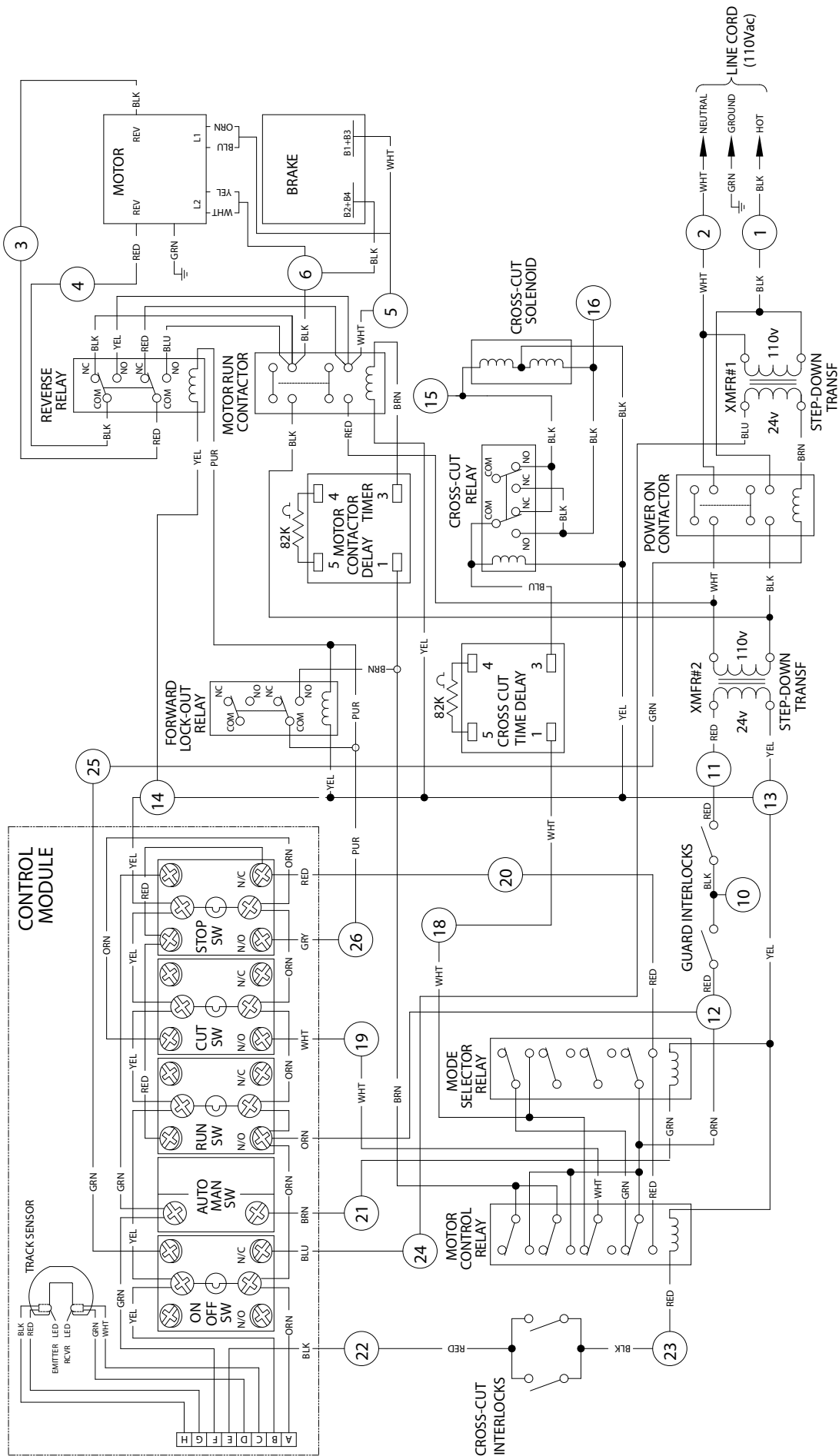

THEORY OF OPERATION

The PLSU2 cutting and slitting section consists of three distinct operating segments. **The:**

- A) motor**
- B) Brake and**
- C) Cross Cut**

- 1)** The motor is turned on or off by the control console sensor after pressing the run switch.
- 2)** Pushing the stop switch or braking the electric eye (deactivating the receiver board) will cause the motor control relay to de-energize in turn de-energizing the motor contactor.
- 3)** The motor run contactor (24VAC) with the mode selector switch in the automatic position the mode selector relay is activated. This relay parallels the run switch and allows the machine to automatically restart once the electric eye is clear of material.
- 4)** The cross cut is activated by depressing the cut switch. This signals the cross cut relay to deactivate one coil of the double solenoid valve and activate the other. This solenoid valve controls the movement of the cross cut cylinder which draws the crosscut blade through the insulation. With the mode selector in the auto mode the mode selector relay is energized. This relay parallels the cut switch allowing the machine to cross cut automatically while the machine is in the auto mode each time the electric eye is interrupted deactivating the motor control relay, a signal is sent to the cross cut relay via the mode selector relay.

SERVICING

It may be necessary to use a voltmeter and or ohmmeter to perform the simple servicing procedures. Follow the instructions below for reading resistance and voltage.

MEASURING RESISTANCE (OHMMETER)

- 1) Disconnect the power supply.
- 2) Set the ohmmeter at RX 1000 scale.

MEASURING AC VOLTAGES (VOLTMETER)

- 1) Set the voltmeter at the nearest scale above (never below) voltage you wish to read.

PLSU2 SPARE PARTS LIST

NOTE: When ordering spare parts include serial number of machine.

Part # Description

17323	Mode Selector Relay
17323	Motor Control Relay
17377	Air Regulator Assembly
28030	Blade Roller
28059	Nylon Roller Bolt
28060	Blade Hub Bolt
28061	Sandpaper Kit
28080	Replacement Blade
28081	Replacement Blade with Hub
28082	Slitter Blade Hub
28083	Hold Down Springs
28084	Friction Slide
28085	Locking Knob
28090	Hold Down Handle
28091	Hold Down Dog
28093	Drive Roller
28094	Slitter Blade Drive Shaft
28097	Feed Drive Shaft
28098	Slitter Drive Gear
28099	Roller Drive Shaft
35055	RR1 Relay
39022	Reverse/Forward Relay

39060	Cross Cut Delay Timer
39084	Roller Plate
39085	Nylon Rollers
39091	Cross Cut Cylinder
39098	Drive Gear
39100	Drive Chain
39101	Chain Link
39103	Cross Cut Relay
39106	24 Volt Transformer
39118	Line Cord
39133	Drive Roller
39172	Guard Interlock
39173	Cross Cut Magnet
39201	Roller Drive Gear
39271	Flat Pillow Block
40001	Drive Cable Tension Spring
40002	Cross Cut Blade w/ Hub
40003	Cross Cut Hub-Bushing
40004	Cross Cut Blade Drivecable
40005	Control Module with Sensor
40006	Material Dispenser Only
44047	Power Contact

**DURO
DYNE**

MACHINERY DIVISION

© 2020 Duro Dyne Corporation
Printed in USA 3/16/2020
BI060009

Duro Dyne East Division, Bay Shore, NY

631-249-9000 Fax: 631-249-8346

Duro Dyne Midwest Division, Hamilton, OH

513-870-6000 Fax: 513-870-6005

Duro Dyne West Division, Longmont, CO

562-926-1774 Fax: 562-926-5778

Duro Dyne Canada, Lachine, Quebec, Canada

514-422-9760 Fax: 514-636-0328

www.durodyne.com E-mail: durodyne@durodyne.com